

Dec. 18, 1956

G. G. BLAISDELL ET AL

2,774,234

TABLE LIGHTER

Filed Jan. 12, 1954

2 Sheets-Sheet 1

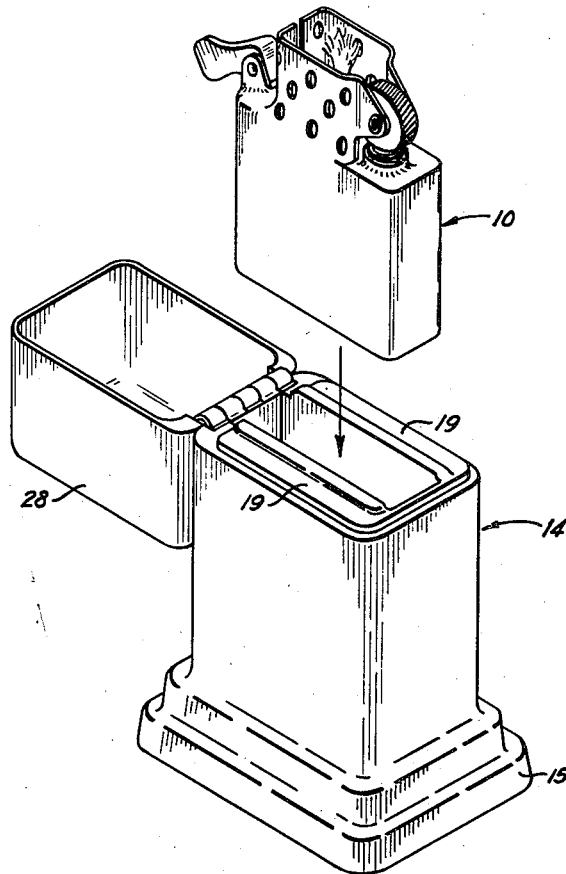

*Fig. 1*

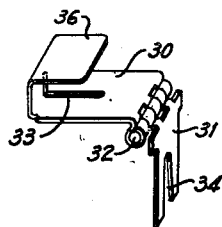

*Fig. 5*

INVENTORS  
GEORGE G. BLAISDELL  
LESTER FLICKINGER  
BY

*Brown, Ritchlow, Hicks & Johnson*  
THEIR ATTORNEYS

Dec. 18, 1956

G. G. BLAISDELL ET AL

2,774,234

TABLE LIGHTER

Filed Jan. 12, 1954

2 Sheets-Sheet 2

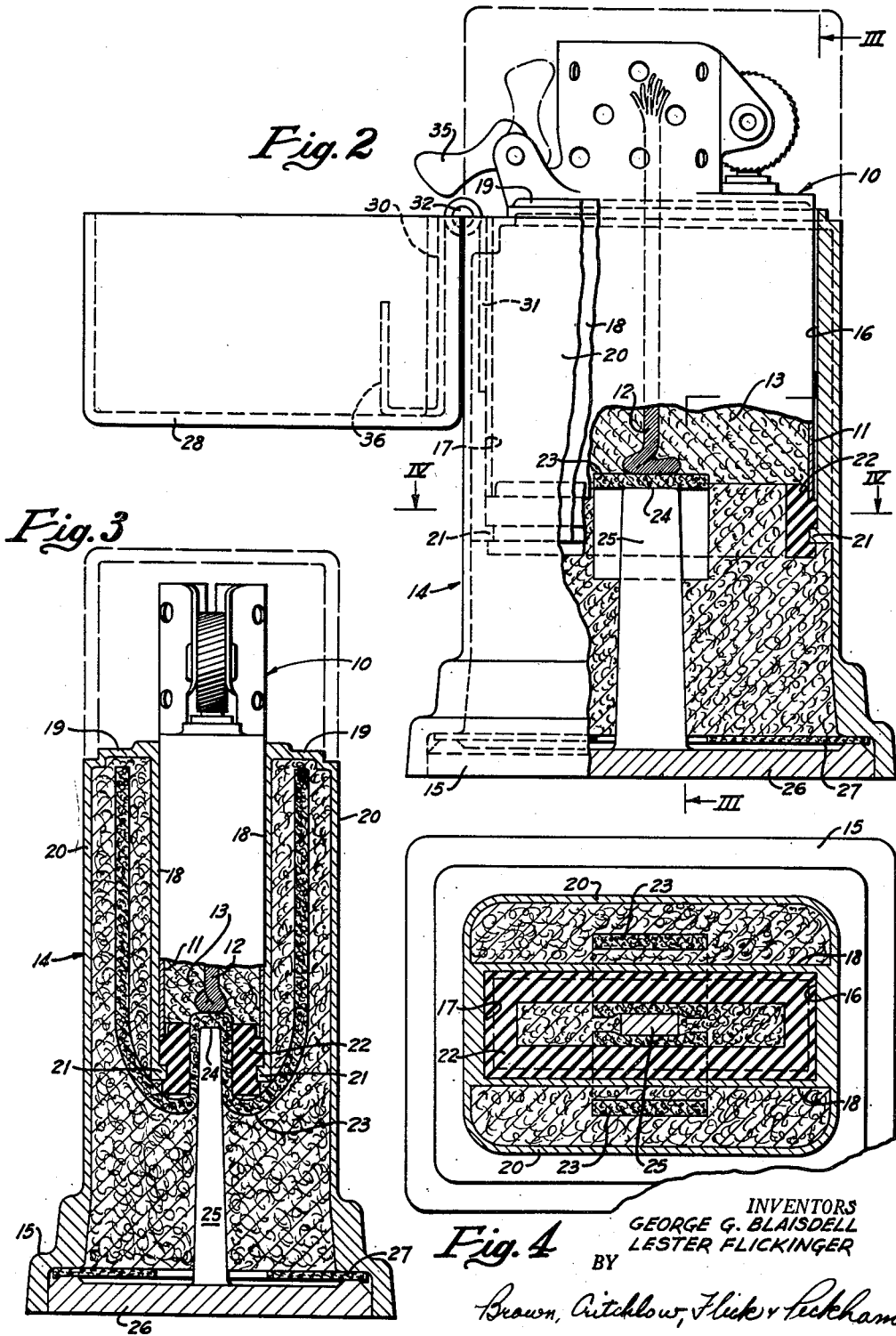

INVENTORS  
GEORGE G. BLAISDELL  
LESTER FLICKINGER

BY

Brown, Aitchison, Flick & Leckham  
THEIR ATTORNEYS

1

2,774,234

TABLE LIGHTER

George G. Blaisdell and Lester Flickinger, Bradford, Pa., assignors to Zippo Manufacturing Company, Bradford, Pa., a corporation of Pennsylvania

Application January 12, 1954, Serial No. 403,611

6 Claims. (Cl. 67—4.1)

This invention relates to a pyrophoric lighter of the type adapted for use on a desk or table.

The invention provides a table lighter that utilizes an insert body of standard design, while providing a greatly enlarged fuel capacity. An extra fuel reservoir is located on each side of the standard lighter insert, and an additional reservoir is provided below the insert body. An auxiliary wick carries fuel from the extra reservoirs to the wick of the insert body. A special gasket is provided to prevent leakage of fuel between the insert body and the table body.

The base of the improved lighter, as well as the cover, are preferably formed of cast material, and a sheet metal hinge member provides a simple and efficient hinge, as well as furnishing a reaction member which cooperates with the cover-control lever.

These and other objects and advantages of the invention will become apparent as the description proceeds.

In the drawings:

Fig. 1 is an exploded isometric view showing the main parts of the lighter.

Fig. 2 is a side elevation, partly in section, of the parts in assembled position.

Fig. 3 is a section on line III—III of Fig. 2.

Fig. 4 is a cross-section on line IV—IV of Fig. 2.

Fig. 5 is an isometric view of the hinge member.

Referring to the drawings more particularly, reference numeral 10 indicates a standard insert body of a lighter sold under the trademark "Zippo" ®. This insert body is formed as a sheet metal casing 11 with an open lower end, and is provided with a wick 12 which extends downwardly in a central location to the lower end of the body. A filling of suitable absorbent material 13, which may be of cotton, surrounds the wick 12 and fills the space within the metal casing 11.

The table body 14 is a casting, preferably a zinc die-casting, having a wide and relatively heavy base 15 which gives the assembled lighter weight and stability.

The upper end of table body 14 is formed with a cavity which receives the insert body 10. The front wall 16 and the rear wall 17 of this cavity have a relatively free fit with the front and rear walls of the insert 10, but the inner partitions 18 closely engage and have a spring-pressed fit with the resilient side walls of the insert 10. This arrangement permits easy removal and replacement of the insert 10, but holds it firmly against the sealing gasket, as will presently be explained.

The internal partitions 18 of the cavity in body 14 connect at their upper ends with the top wall 19, which extends from the front wall 16 to the rear wall 17, as clearly shown in Fig. 1. The inner partitions 18 also extend the full width of the body 14 from the front wall 16 to the rear wall 17, and are spaced inwardly a considerable distance from the outer walls of body 14 (see Fig. 3). The result of this construction is that the table body 14 is of substantially the same width as the insert body 10, but is of considerably greater thickness. The

2

greater thickness is due to the space between the inner side walls 18 and the outer side walls 20 of the body 14. These spaces provide a fuel reservoir on each side of the insert body 10.

At the lower end of each of the inner side walls 18, there is formed an inward flange 21, and this inward flange connects with similar flanges formed on the front wall 16 and rear wall 17 (see Fig. 2), so that the flange 21 extends continuously around the cavity formed in body 14.

The flange 21 is located a short distance below the lower edge of the sheet metal casing 11 of the insert body 10, and the space between these two parts is sealed by a special gasket 22. This gasket, which may be formed of Neoprene ®, or other resilient material that is not affected by lighter fluid, is of hollow rectangular shape and fits closely within the inner walls 18 and front and rear walls 16 and 17. Gasket 22 is provided with a groove which fits over the flange 21 and holds the gasket in place.

When the insert body 10 is pressed down into the cavity in the upper end of the table body 14, the lower edge of the sheet metal casing 11 engages the gasket 22, compressing the gasket against the flange 21, and thus effectively sealing the joint between the insert body 10 and the table body 14.

The space in the table body 14 below the flange 21 provides a bottom reservoir for lighter fluid in addition to the storage reservoirs provided on each side of the insert 10, as described above. All of this reservoir space in the body 14 is filled with some suitable absorbent material, such as cotton, and when the lighter is in use this cotton is saturated with lighter fluid. In order to carry the lighter fluid from the reservoir of the table body 14 to the cotton filling and the wick of the insert body 10, an auxiliary wick 23 is provided.

The wick 23 is disposed in a generally U-shaped position with each arm of the U extending upward into one of the storage reservoirs located alongside of the insert body 10. In order to bring wick 23 into direct and positive contact with the wick 12 and the cotton filling of the insert body 10, the lower portion or bight 24 of wick 23 is pushed upwardly through an opening formed in the gasket 22. This positioning of the bight 24 is accomplished by a projection 25 which extends upwardly from the bottom closure plate 26. When the parts are in assembled position, the standard 25 projects upwardly to approximately the upper surface of the gasket 22. The bight 24 extends over the top of standard 25, and is thereby brought into direct and positive contact with the lower end of wick 12, and with the cotton filling of the insert body 10.

The bottom closure plate 26 has a close press fit in the body 14, and a suitable gasket 27 seals the joint between plate 26 and body 14.

Another feature of the invention resides in the means used to hinge the cover 28 to the table body 14. The cover 28 is formed like the body, preferably as a zinc die-casting, and its lower edge fits into a recess 29 formed in the top wall 19 of body 14. When the cover is closed, as in Fig. 3, the outer surfaces of the cover lie in the same plane as the outer surfaces of body 14, thereby giving the lighter a smooth and clean-cut appearance.

In order to provide a simple and efficient hinge, two sheet metal hinge plates, 30 and 31 (see Fig. 5) are bent about a hinge pin 32 to form a hinge member. The hinge plate 30 fits into a pocket formed in the cover. The plate 30 is slotted at 33 and the sides of the pocket converge toward the bottom to press inwardly on the edges of plate 32, partially closing slot 33 and thus creating a re-

3

resilient frictional grip when the plate 32 is pressed into the pocket.

Similarly plate 31 is slotted at 34, and when pressed into a pocket having tapered sides in the body 14, is secured to the body 14 by a resilient frictional grip.

The insert body 10 carries as part of its mechanism a cover-control lever 35, which functions to hold the cover closed as disclosed in Gimera Patent No. 2,032,695. To thus function it is necessary to provide the cover with a reaction member against which the cover-control lever can press when the cover is closed. In the present case this reaction member is provided by bending up the end of hinge plate 30 to form the reaction member 36. The plate 30 is first bent up to form an end wall and then bent inwardly to form the reaction member 36, which is parallel to, but spaced from, the main body of the hinge plate 30. This construction is very simple and efficient, since the reaction member 36 is formed as part of the steel hinge member and is therefore strong and resistant to abrasion by the cover-control lever.

It should be understood that to fill the lighter with lighter fluid, it is only necessary to remove the insert body 10 and pour lighter fluid into the cavity of the table body 14. The insert body 10 is then reinserted, and is pressed down against the gasket 22 which effectively seals the joint between the insert body 10 and the lighter body 14. The gasket 27 seals the only other opening in body 14, so that the volatile lighter fluid is very effectively confined within the lighter against loss by evaporation.

All of the lighter fluid from the large reservoirs in the body 14 are readily available because the U-shaped wick 23 acts by capillary action to carry the fluid from the reservoirs of the enlarged table body 14 directly to the wick 12 and the cotton filling of the insert body 10.

While the table body 14 and cover 28 have been described as zinc die-castings, it should be understood that these parts may be plated or provided with any other suitable decoration.

According to the provisions of the patent statutes, we have explained the principle of our invention and have illustrated and described what we now consider to represent its best embodiment. However, we desire to have it understood that, within the scope of the appended claims, the invention may be practiced otherwise than as specifically illustrated and described.

We claim:

1. A table lighter of the type in which an insert body carrying the lighter mechanism is inserted in a table body having a fuel reservoir, the improvement which comprises: the insert body having a shape which is rectangular in cross section, and having a wick surrounded by absorbent material, the table body being provided with a cavity which receives the insert body, the table body being provided with a side fuel reservoir disposed on each side of the insert body, and with a bottom fuel reservoir located below the insert body, and a resilient gasket disposed below the insert body to seal the joint between the insert body and the table body.

2. A table lighter of the type in which an insert body carrying the lighter mechanism is inserted in a table body having a fuel reservoir, the improvement which comprises: the insert body having a shape which is rectangular in cross section, the table body being provided with a cavity which receives the insert body, said cavity being defined by front and rear walls of the table body, and by a pair of inner partitions, an inward flange projecting from the front and rear walls of the table body and from the lower edges of the inner partitions, a resilient gasket of rectangular shape fitting over the inward flange, and sealing the space between the lower edge of the insert body and said flange.

3. A table lighter of the type in which an insert body carrying the lighter mechanism is inserted in a table body having a fuel reservoir, the improvement which comprises: the table body having a top wall and side walls,

4

a pair of inner partitions depending from the top wall, the partitions being spaced inwardly from the side walls of the table body to provide fuel reservoirs, and an insert body inserted between the inner partitions, the inner partitions being spaced apart such a distance as to closely engage the sides of the insert body, the insert body being provided with a wick surrounded by absorbent material, and said fuel reservoirs being filled with an absorbent material, the table body having a U-shaped auxiliary wick, the arms of which extend into the reservoirs, and with the bight of the U being in contact with the absorbent material of the insert body to make fuel from the body reservoirs available to the wick of the insert body.

4. A table lighter of the type in which an insert body carrying the lighter mechanism is inserted in a table body having a fuel reservoir, the improvement which comprises: the table body having a top wall and side walls, a pair of inner partitions depending from the top wall, the partitions being spaced inwardly from the side walls of the table body to provide side fuel reservoirs, the inner partitions ending partway down the height of the table body to provide a bottom fuel reservoir, an insert body of rectangular cross section inserted between the inner partitions, the inner partitions being spaced apart such a distance as to closely engage the sides of the insert body, the insert body being provided with a wick surrounded by absorbent material, and the side fuel reservoirs and the bottom fuel reservoir being filled with absorbent material, and the table body having an auxiliary wick disposed in the shape of a U with one arm of the U extending into each of the side reservoirs, and with the bight of the U extending into the bottom reservoir and being in contact with the absorbent material of the insert body to make fuel from the body reservoirs available to the wick of the insert body.

5. A table lighter of the type in which an insert body carrying the lighter mechanism is inserted in a table body having a fuel reservoir, the improvement which comprises: the insert body having a shape which is rectangular in cross section, and having a wick surrounded by absorbent material, the table body being provided with a cavity which receives the insert body, the table body being provided with a side fuel reservoir disposed on each side of the insert body, and with a bottom fuel reservoir located below the insert body, a resilient gasket disposed below the insert body to seal the joint between the insert body and the table body, the side fuel reservoirs and the bottom fuel reservoir of the table body being filled with absorbent material, and the table body having an auxiliary wick disposed in the shape of a U with one arm of the U extending into each of the side reservoirs and with the bight of the U passing through the bottom reservoir and extending upwardly through the resilient gasket to contact the absorbent material of the insert body to make fuel from the reservoirs of the table body available to the wick of the insert body.

6. A table lighter of the type in which an insert body carrying the lighter mechanism is inserted in a table body having a fuel reservoir, the improvement which comprises: the insert body having a shape which is rectangular in cross section, the table body being provided with a cavity which receives the insert body, said cavity being defined by front and rear walls of the table body, and by a pair of inner partitions, an inward flange projecting from the front and rear walls of the table body and from the lower edges of the inner partitions, a resilient gasket of rectangular shape fitting over the inward flange, and sealing the space between the lower edge of the insert body and said flange, the table body being provided with two side fuel reservoirs located at opposite sides of the insert body and with a bottom fuel reservoir located below the insert body, the insert body having a wick surrounded by absorbent material, the resilient gasket having a central opening, an auxiliary wick disposed in the shape of a U with one arm of the U extending into

**5**

each of the side reservoirs, and with the bight of the U passing through the bottom reservoir and extending upward through the opening in the resilient gasket, a bottom closure plate closing the lower end of the table body, and a projection which extends upwardly from the bottom closure plate into the opening in the resilient gasket, the projection holding the bight of the U-shaped auxiliary wick in contact with the absorbent material of the insert body, thereby making fuel from the reservoirs of the table body available to the wick of the insert body.

**5****10****6****References Cited in the file of this patent****UNITED STATES PATENTS**

1,061,074	Heym -----	May 6, 1913
2,243,065	Barrett -----	May 27, 1941
2,464,524	Nathan -----	Mar. 15, 1949
2,480,139	Keene -----	Aug. 30, 1949
2,490,300	Hettinger -----	Dec. 6, 1949
2,551,107	Eratico -----	May 1, 1951
2,583,350	Witzgall -----	Jan. 22, 1952